

Direct Bonding of Glass and Metal Using Short Pulsed Laser

Akihiro UTSUMI*, Toshihiko OOIE*, Tetsuo YANO** and Munehide KATSUMURA**

* *Biodevice Team, Health Technology Research Center, National Institute of Advanced Industrial Science and Technology (AIST), 2217-14 Hayashi-cho Takamatsu, Kagawa 761-0395, Japan*
E-mail: utsumi.a@aist.go.jp

** *Collaboration Center, National Institute of Advanced Industrial Science and Technology (AIST), 2217-14 Hayashi-cho Takamatsu, Kagawa 761-0395, Japan*

Generally, brazing, involving the insertion of the molten metal, is the method used for bonding glass and metal. In this study, we tried to bond glass and metal directly. That is, we brought glass and metal into contact and bonded them by irradiating the surface of the metal with a short pulsed laser through the glass. By this method, the average temperature of the materials remained cold at bonding. This bonding method seems to able metal grains that adhere to the glass anchoring the metal. However, when the irradiation was conducted too many times, or when the irradiation energy was too large, cracks and pitting may be produced on the glass surface.

Keywords: Pulsed laser, glass, metal, bonding, shearing strength, crack

1. Introduction

In recent years, technology for bonding metal electrodes to glass has been widely applied, such as in measurement hardware, solar batteries, and touch panels. Methods for bonding metal to glass include brazing, metallizing, active metal soldering, anode bonding, etc.[1] To bond copper to glass using such methods, it is necessary to bond an undercoating metal to the glass beforehand. The time, effort and cost required in making the undercoating layer are burdens of the conventional method. Some applications use heavy metal, with the possibility of a negative influence on the environment. Recently, a study involving the deposition of a metal film on glass using a laser was reported by Hidai, etc.[2]

In this study we investigated a method for bonding copper to glass directly. We brought a small metal ball into direct contact with glass, and irradiated it with a short pulse laser from the glass side.

2. Experimental

2.1 Specimen

Fig. 1 shows a schematic diagram of the equipment used for the bonding experiment. A 532 nm Nd:YAG laser (Minilite, made by Continuum) was used as the pulsed laser. The pulse width was about 5 ns. The energy of the laser beam was decreased to a predetermined value by changing the angle of the polarizer. The laser beam was reflected downward with a dichroic mirror, and a focusing lens was positioned to focus the beam on the surface of the copper ball specimen. A CCD camera and its imaging lens were set on the same axis as focusing lens. The CCD camera was also focused on the surface of the specimen. When arranging a specimen, we viewed the image from the CCD camera and adjusted the irradiation position and the focus of the laser on the top of the copper ball. In addition, we placed a jig made from stainless steel on a table which can be moved about 5 mm in three directions, XYZ.

Copper balls (100-150 μ m in diameter, purity 99 %) were created by the atomizing method. A borosilicate cover

glass, as used with an optical microscope, was used for the specimen. To immobilize the ball, a pyramidal hole (diagonal length about 100 μ m) was made in the jig. We placed the copper ball in the hole, and placed the cover glass on the ball. To fix the cover glass, we placed a BK7 glass plate over it and a dead weight with a hole through the center.

Table 1 shows the conditions under which we conducted the bonding experiment. We made four test pieces for each condition.

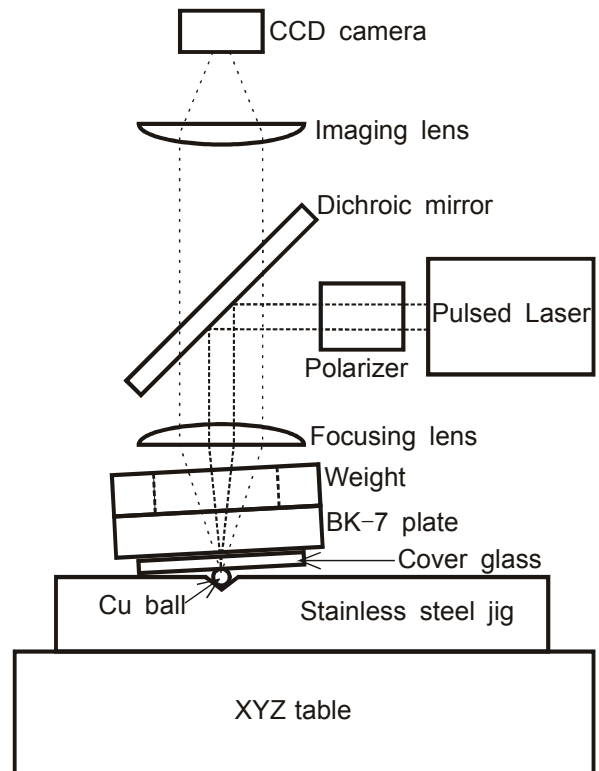

Fig. 1 Schematic diagram of the bonding equipment.

Table 1 Experimental conditions

Laser	Q-switched Pulse width: 5ns
Copper	Diameter: 100-150 micrometers, Purity: 99%
Glass	Thickness: 0.17mm, Borosilicate glass
Pulse energy	75, 100, 150, 200, 300, 400 μ J
Number of shots	1, 2, 3

2.2 Observation of the bonding area

Before the shear test, we observed and photographed the area where the copper ball was bonded to the cover glass with an optical microscope from the cover glass side. We also investigated microscopically whether cracks existed on the surface or inside the cover glass. After the shearing test, we observed the area where the copper ball had bonded with the optical microscope, and characterized the state of the bonding area.

2.3 Measurement of shearing strength

A schematic diagram of the equipment used for the measurement of shearing strength is shown in Fig. 2. We fixed the non-bonded side of the glass specimen to the vertical plane of the jig with double-sided adhesive tape. We placed a stainless wire (diameter 20 μ m) against the cover glass, beneath the bonded ball, as in Fig. 2.

Using an actuator, pulled the wire up slowly, and measured the decrease of weight with the electronic balance. We compared the area where the bond had sheared with the photographs of the bond before shearing and investigated shearing strength.

3. Results and Discussion

3.1 Appearance of the bonding area

Fig. 3 shows the bond between the copper ball and the cover glass, taken with an optical microscope through the cover glass, after irradiation once only with different pulse energies. The melted zone of the copper ball was almost circular, occupying a diameter of about 50 - 80 μ m. The size of the melted zone increased with increasing irradiation energy of the pulsed laser. We assume that the higher pulse energies increased the temperature of the irradiated zone, resulting in a larger melt zone.

Fig. 4 shows the bonded area through the cover glass for an increasing number of irradiations at a constant laser pulse energy of 200 μ J. As the number of times of irradiation increased, the size of the melted zone became slightly larger.

Fig. 5 shows a highly magnification of the bonded area taken by microscope through the cover glass. There were many copper particles of about 5 μ m or less in the bonding area and around it. The larger particles indicate that the melted copper spilled out of the immediate contact circumference and adhered around the bonding area. Almost all the particles inside the bonding area were about 1 μ m or less. The number of particles seemed to increase with in-

creasing irradiation energy of the laser and the number of irradiation exposures.

Therefore, at the time of laser irradiation, it is presumed that copper evaporated in the central part of the melting area pushing melted particles from the surface of the copper ball out to the circumference of the bonding area where they adhered to the cover glass. The melted area appeared to solidify quickly. It is thought that the mean temperature of the cover glass was hardly raised.

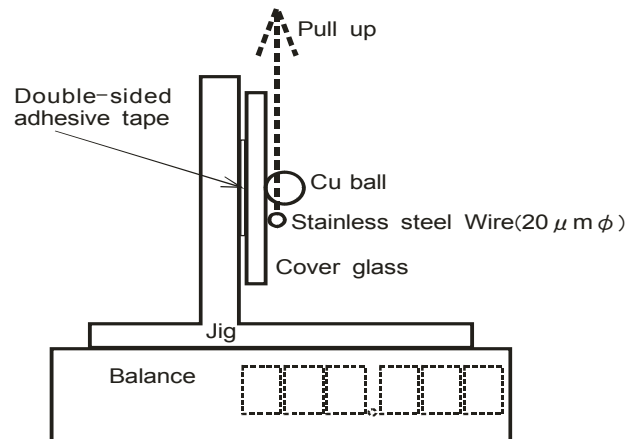

Fig. 2 Schematic diagram of the equipment for measurement of shear strength.

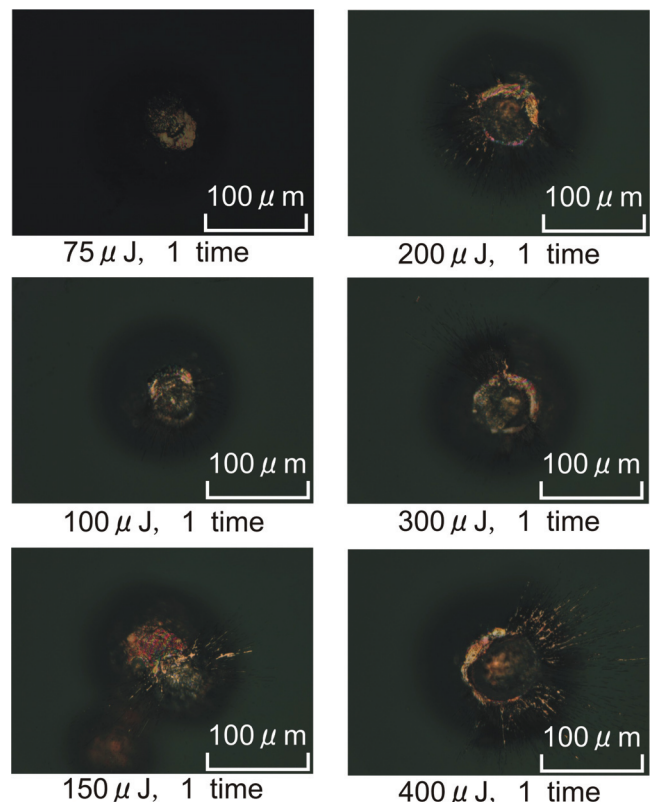

Fig. 3 Appearance of the bonding area through the cover glass for a single irradiation at various pulse energies.

Adhesion of the particles can be seen in the central part of the bonding area, but don't seem to contribute much to the strength of the bond. At the circumference, the melted copper and the cover glass seemed to be in direct contact, and contribute most of the bond strength. It is presumed that the actual area which contributed to the strength of the bond was just a part of the melted zone of the copper ball.

Cracks were seen in the bonded area interface and inside the cover glass of some specimens. It seemed that the glass cracked more often when the irradiation energy of laser became large, or when the frequency of irradiation increased. However, the few specimens in which cracking did not occur in the cover glass were the specimens with large bonding strength. This seems to show the possibility of directly bonding glass and copper.

3.2 Shear strength

Fig. 6 shows a sample shearing test result when the sample was irradiated twice at a pulse energy of 300 μ J. In this case the shearing strength was 4.4mN. Under every condition, the shearing strength varied greatly, and the minimum shearing strength was 0 kPa for almost all conditions. In all specimens, the copper ball was separated from the glass by the shearing test. It is thought that by this method a relative comparison of shearing strength can be performed

Fig. 7 shows the maximum value of the shearing

strength in each laser irradiation condition. Up to a laser irradiation energy of 400 μ J, it seems that shearing strength increases with an increase in energy. However, the shearing strength at 500 μ J was small. No tendency was seen for the frequency of irradiation.

For the specimen in which the whole melt zone of a copper ball had contributed to bonding, the bonded area diameter was 80 μ m, the shearing strength was 870 kPa. This sample had been irradiated twice at the pulse energy of 300 μ J.

Fig. 8 shows the bonding area of a cover glass, observed with an optical microscope directly the bonding side, after a shearing test. When pulse energies were 75 μ J as shown in Fig. 8, copper particles sometimes remained in the bonding area after the shearing test. No cracks were seen on the surface or inside the cover glass in the case of this specimen. Under the other irradiation conditions, after the shearing test, copper seldom remained in the bonding area.

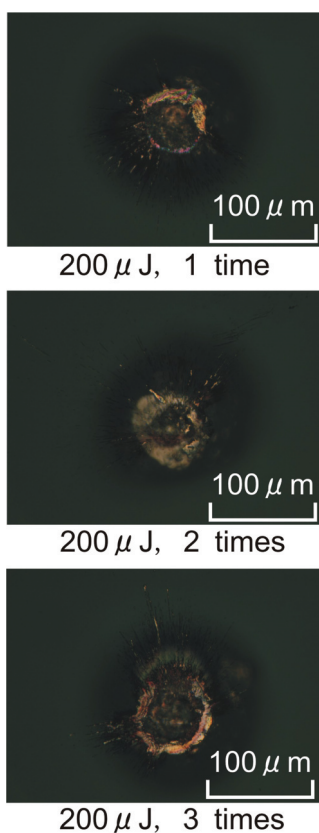

Fig. 4 Appearance of the bonding area, after multiple irradiations at 200 μ J of pulse energy.

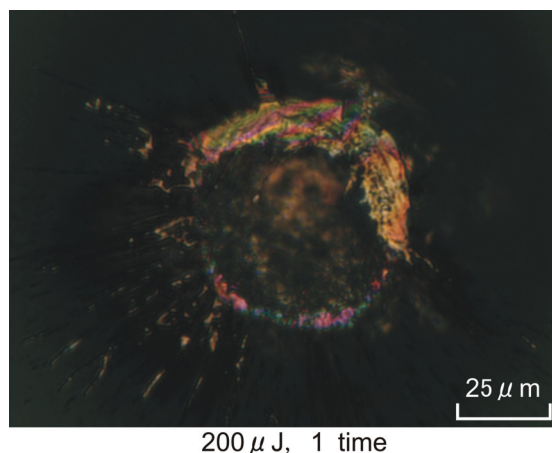

Fig. 5 Higher magnification of the bonding area, through the cover glass.

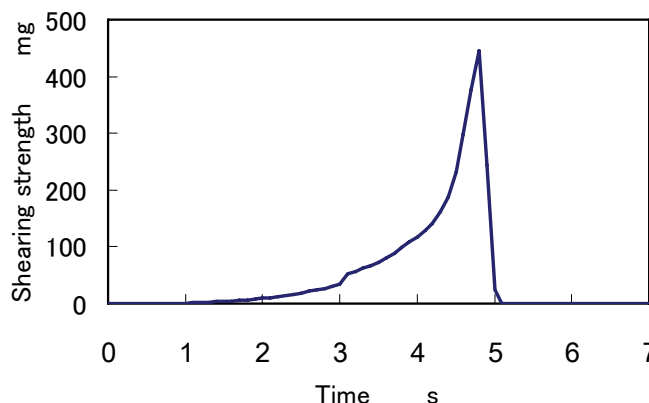

Fig. 6 Single shearing test result.

4. Conclusions

We tried to bond borosilicate glass and a copper ball directly with a pulsed laser, and arrived at the following conclusions.

- 1) Direct bonding of borosilicate glass and the copper ball could be achieved without cracking the glass.
- 2) The maximum shearing strength of the bond was 690 kPa in the case of the specimen irradiated twice at a pulse energy of 300 μ J.
- 3) The size of the melted zone was increased with increasing irradiation energy of the pulsed laser.
- 4) Copper particles increased, with increasing and frequency of irradiation.
- 5) The shearing strength trended to increase up to a pulse energy of 400 μ J, but not higher.

References

- [1] "Yousetsu-Setsugo Binran"(in Japanese), ed. by Japan Welding Society,(Maruzen, 2004) 1053.
- [2] M. Hidai, L. Fan and H. Tokura: Seimitsukogakkai-shi(in Japanese), **66**, (2000) 1740.

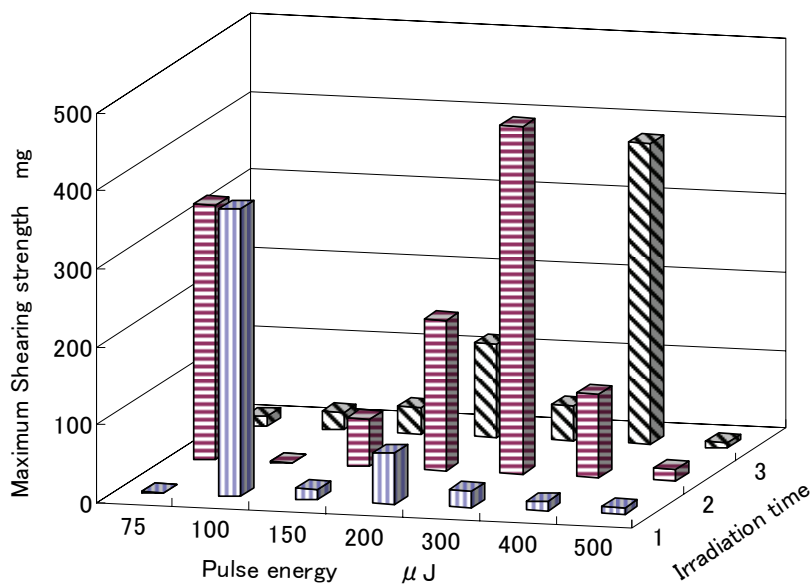
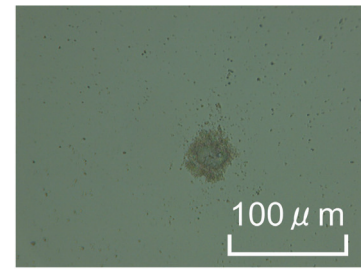
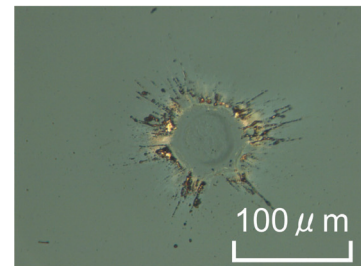

Fig. 7 Maximum shearing strength versus irradiation energy and frequency.



75 μ J, 2 times



200 μ J, 2 times

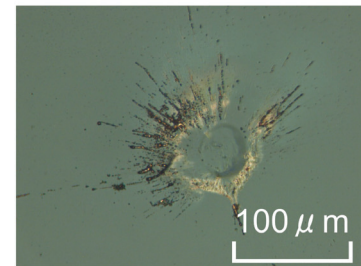

300 μ J, 2 times

Fig. 8 Post-test appearance of the bonding area of the cover glass, viewed directly.

(Received: March 30, 2007, Accepted: April 20, 2007)